

HEAVY DUTY BARRELS

Manufactured using prime grade US Food & Drug Administration Approved Polyethylene
Seamless, one piece construction. Rugged, industrial strength, chemical & impact resistant.



Manufactured by:

Lot C, Don Miguel Extension Rd. San Juan, Trinidad W.I.
T 868 674 8265 F 868 674 8339 www.rotoplastics.co.tt

 **ROTOPLASTICS**
TRINIDAD LIMITED

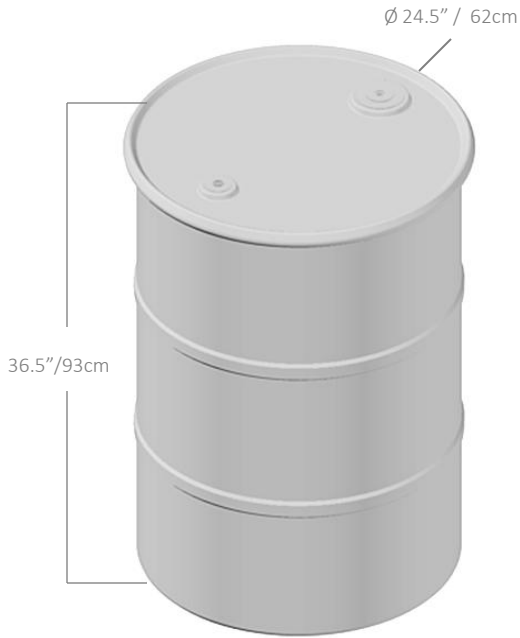

55 US Gallons • 208 Litres
23 lbs • 10 kg

Do not stack more than three (3) barrels high

Not made to store :

- Gasoline / Diesel
- Product filled at over 160F (71)
- Products requiring hermetic (vacuum) seal

Standard Colours: Natural, Blue & Yellow. Other colours available on request.

DROP TESTED FROM 8 FEET

View video on : youtube <http://youtu.be/qq8p9IE3zsz>

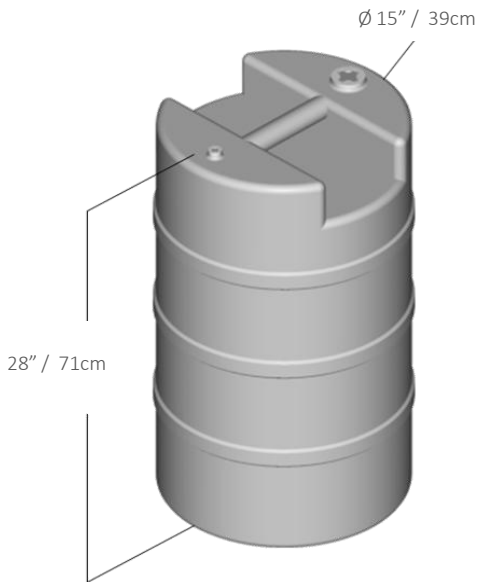

20 US Gallons • 76 Litres
10 lbs • 4.5 Kilos

Not made to store :

- Gasoline / Diesel
- Products requiring hermetic (vacuum) seal

Standard Colours: Natural & Yellow. Other colours available on request.

Fittings:



Standard Closures Included 2" & 3/4" NPT Plugs